

Brute

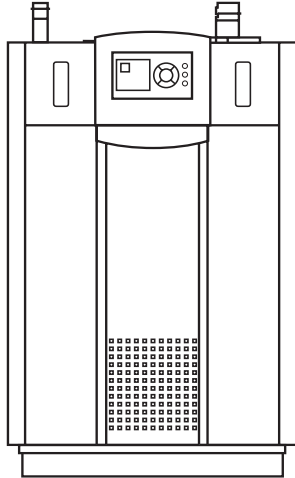

Residential Hydronic Boiler

BNTH | Hydronic Boiler

Indoor Sizes 080-210

Submission Data **BRADFORD WHITE**

Date:

Project #:

Engineer:

Prepared By:

Bid Date:

Project Name:

Location:

Contractor:

Standard Equipment

- Large LCD display with touchpad user-interface
- Quick start feature for basic installations
- Password-protected parameters for installer use
- Customizable display screen and LCD contrast
- Test feature allows forced min or max firing
- Complete on-screen diagnostics
- Displays in clear text form
- High condensing efficiency
- Modulation down to 20% of full fire (5:1 turndown)
- Sealed combustion chamber
- Pre-mix stainless steel burner
- Low NOx system exceeds the most stringent regulations for air quality – 10ppm NOx
- Horizontal or vertical direct vent
- Horizontal vent and air terminals
- Vent and air pipe lengths of up to 100 equivalent feet (each)
- Built-in condensate trap
- Vent temperature cutoff
- Indirect water heater priority (sensor included)
- ASME 30 psi (207 kPa) working pressure heat exchanger (50 psi optional)
- Stainless steel heat exchanger with welded construction
- ASME "H" stamp
- 30 psi (207 kPa) ASME rated pressure relief valve
- Temperature and pressure gauge
- Drain valve
- Multiple pump control for boiler pump, system pump and indirect domestic water pump, each with delay
- Optional pump (sized to model) available for field installation
- Electronic PID modulating control
- Direct spark ignition
- Integrated PID temperature and ignition controls
- Alarm output
- Accepts external (4- 20mA or 0-10VDC) modulation signal
- Outdoor reset (sensor included)
- On/Off toggle switch
- Manual reset high limit
- Burner site glass
- Flue gas temperature cutoff
- Zero clearance to combustible surfaces
- Meets Energy Star 'Most Efficient' criteria
- 12-year limited warranty

Boiler Data

Number of Units:

Fuel

- Natural
 Propane

Pump Options

- Pump-included
 No pump

Factory Mounted Options

- 50 psi rating and relief valve
 Alarm bell for ignition failure with silencing switch
 Additional automatic reset high limit
 Color touch-screen display



Sizing Data

Model	Input		Output		AFUE	Gas Conn. Size inches	Water Conn. Size inches	Product Weight		Shipping Weight	
	BTU/h	kW	BTU/h	kW				lbs	kg	lbs	kg
<input type="checkbox"/> BNTH 080	80,000	23.4	74,000	21.7	95%	1/2 NPT	1 NPT	130	59	202	92
<input type="checkbox"/> BNTH 105	105,000	30.8	96,000	28.1	95%	1/2 NPT	1 NPT	155	70	216	98
<input type="checkbox"/> BNTH 150	150,000	44.0	138,000	40.4	95%	1/2 NPT	1 NPT	180	82	228	104
<input type="checkbox"/> BNTH 210	210,000	61.5	194,000	61.5	95%	1/2 NPT	1 NPT	195	88	270	123

NOTES:

1. For other boiler ratings:

$$\text{Boiler Horsepower: HP} = \frac{\text{Output}}{33,475} \quad \text{Radiation Surface: EDR sq. ft.} = \frac{\text{Output}}{150}$$

Accessories for Field Mounting

<input type="checkbox"/> Water flow switch	<input type="checkbox"/> 2" Flush-mount terminal	<input type="checkbox"/> Vari-prime variable speed pump control
<input type="checkbox"/> Low water cutoff	<input type="checkbox"/> 3" Flush-mount terminal	<input type="checkbox"/> Color touch-screen display upgrade
<input type="checkbox"/> 3" Concentric vent terminal	<input type="checkbox"/> Propane conversion kit	
<input type="checkbox"/> High & Low gas pressure switches	<input type="checkbox"/> Condensate neutralizer kit	
<input type="checkbox"/> 2" Concentric vent terminal	<input type="checkbox"/> BACnet gateway	
<input type="checkbox"/> Boiler pump	<input type="checkbox"/> LON gateway	

Clearances

Appliance Surface	Required Clearance from Combustible Material		Suggested Service Access Clearance	
	inches	cm	inches	cm
Left Side	1	2.5	1	2.5
Right Side	1	2.5	12	31
Top	1	2.5	24	61
Back	1	2.5	6	15
Closet, Front	1	2.5	6	15
Alcove, Front	1	2.5	24	61
Vent	0	0	–	–

Vent System

Max Equivalent* Vent and Air Pipe Length
(each)

Size	2" dia / 5.1cm	3" dia / 7.6cm
080	40 ft 12.2m	100 ft 30.5m
105	40 ft 12.2m	100 ft 30.5m
150	n/a	100 ft 30.5m
210	n/a	100 ft 30.5m

Intake (air) pipe may be PVC, CPVC, ABS or galvanized pipe.

Installations in the U.S. require exhaust vent pipe that is PVC or CPVC complying with ANSI/ASTM D1785 F441 or stainless steel complying with UL1738. Laars supplies the first section of vent pipe which is 16" of CPVC with each boiler. Installations in Canada require exhaust vent pipe that is certified to ULC S636.

*To calculate equivalent length, measure the linear feet of the pipe, and add 5 feet (1.5m) for each elbow used.

Dimensional Data

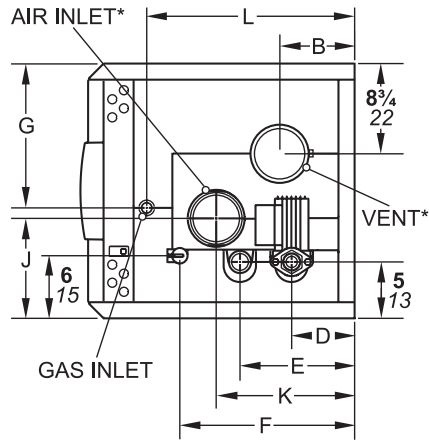

* Brute is shipped with adapters for the air and vent that accept standard pipe of the proper size and type.

TOP VIEW

Optional Pump Location
(field-mounted for 285-500 only)

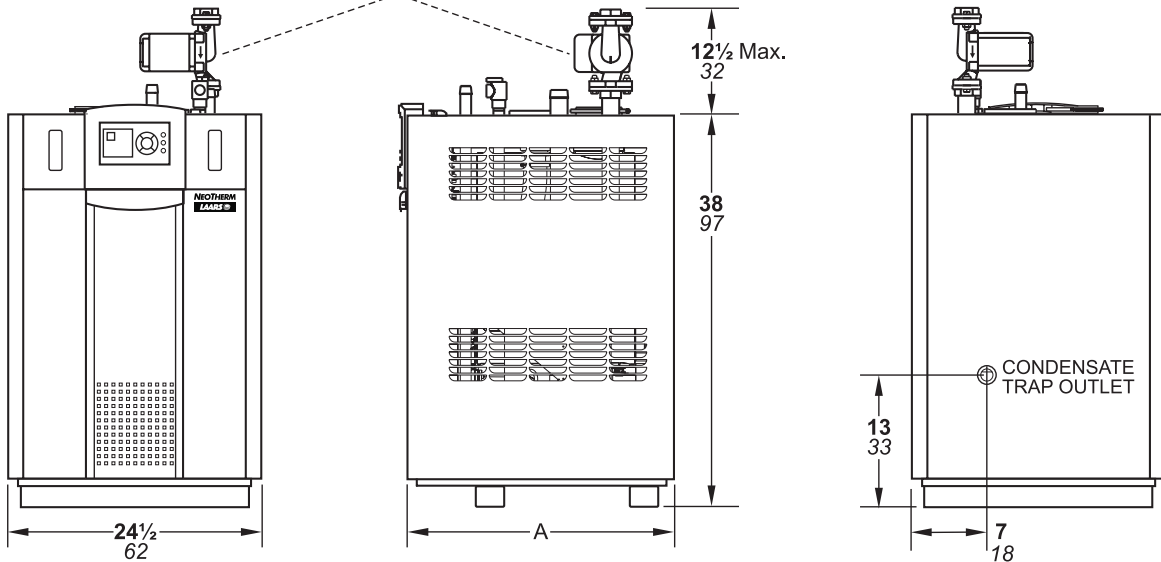

FRONT VIEW

RIGHT SIDE VIEW

BACK VIEW

BNTH SIZE	A IN	B IN	WATER INLET D IN	WATER OUTLET E IN	F IN	G IN	J IN	PRV OUTLET K IN	L IN	AIR INLET* IN	VENT* IN
80	19 1/2	9 1/2	7 1/2	11	10 3/4	13 3/4	3 1/2	11 3/4	13 1/2	2	2
105	19 1/2	8	6 1/4	11	9	14 1/4	3 1/2	11 3/4	13 1/2	2	2
150	19 1/2	5 1/4	3 1/4	11	7 1/2	14 1/4	5	7 1/2	13 1/2	3	3
210	26 3/4	5 1/4	3 1/4	18	11 3/4	14 1/4	5	7 1/2	20 1/2	3	3
	CM	CM	CM	CM	CM	CM	CM	CM	CM	CM	CM
80	49	24	19	28	27	35	9	30	34	5	5
105	49	21	16	28	22	36	9	30	34	5	5
150	49	14	8	28	19	36	13	19	34	7	7
210	68	14	8	45	30	36	13	19	52	7	7

**Electrical
Data**

Sizes	Boiler			Pump Connections Ratings (System Pump and DHW Pump Connections)
	Volts	Phase	Amps	
80-210 No Pump	120	Single	2*	115V – Maximum 1HP or 7.4A max
080–210 With Pump	120	Single	Less than 6*	115V – Maximum 1HP or 7.4A max

* Minimum 15A circuit required

**Water Flow
Requirements**

Size	Temperature Rise in °F									
	20°F		25°F		30°F		35°F		40°F	
	Flow gpm	H/L feet	Flow gpm	H/L feet	Flow gpm	H/L feet	Flow gpm	H/L feet	Flow gpm	H/L feet
080	7.6	14.9	6.1	10.1	5.1	7.1	4.3	5.8	3.8	4.6
105	10.0	23.1	8.0	17.0	6.7	12.4	5.7	9.6	5.0	7.6
150	14.3	28.5	11.4	19.0	9.5	13.6	8.1	11.2	7.1	8.8
210	20.0	24.1	16.0	16.7	13.4	11.6	11.3	9.0	9.9	6.9

Size	Temperature Rise in °C									
	11°C		14°C		17°C		19°C		22°C	
	Flow lpm	H/L m	Flow lpm	H/L m	Flow lpm	H/L m	Flow lpm	H/L m	Flow lpm	H/L m
080	29	4.5	23	3.1	19	2.2	16	1.8	14	1.4
105	38	7.0	30	5.2	25	3.8	22	2.9	19	2.3
150	54	8.7	43	5.8	36	4.1	31	3.4	27	2.1
210	76	7.3	61	5.1	51	3.5	43	2.7	37	2.4

Note that pumps are sized for a) 25-30°F temperature rise across the boiler;
b) 30 feet of external boiler loop piping (1"); c) six 90° elbows.

Bradford White reserves the right to change specifications, components, features, or to discontinue products without notice.



200 Lafayette St.
Middleville, MI 49333
Warranty: (800) 531-2111

www.BradfordWhite.com

Litho in U.S.A. © Bradford White 1508 Document 1221H-BW